

BATTERY & CHARGER STATIONS

CHARGER ACCESSORIES

COMPLETE LINE

- *Most comprehensive line of products and accessories for your battery charger.*

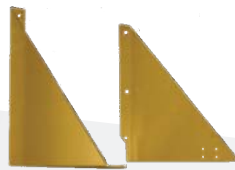

BATTERY HANDLING SYSTEMS



BATTERY & CHARGER STATIONS

CHARGER ACCESSORIES

CHARGER STANDS (CS)

BHS Charger Stands come in several models and provide a safe, convenient location for your battery chargers.

FEATURES & BENEFITS

- *Heavy duty frame construction for added reliability*
- *Standard models available: 24", 36" and 72"*
- *24" and 36" models have a 400 lbs shelf capacity
72" model shelf capacity is 600 lbs*
- *Custom built models made to your specifications*
- *CR-1 cable retractor mounting holes*
- *SB connector mounting holes*
- *Charger shelves come slotted allowing for optional 6" shelf extension*
- *Charger anchoring slots for securing most makes of chargers*
- *Fluid corners on the charger shelf increases product longevity*

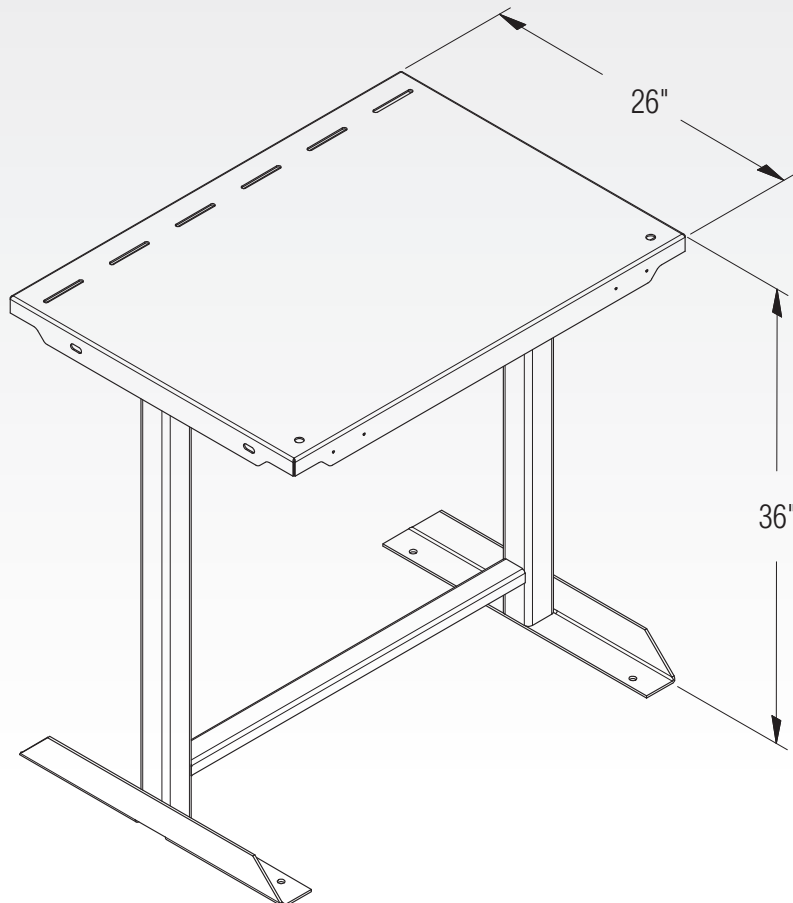
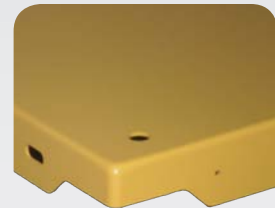

CHARGER WALL BRACKETS (CWB)

Charger Wall Brackets (CWB) offer an economical solution for mounting battery chargers. The CWB is sturdy and easy to install.

FEATURES & BENEFITS

- Helps prevent charger damage
- Supports up to 400 lbs
- 24-1/8" deep x 24-1/8" tall



CWB

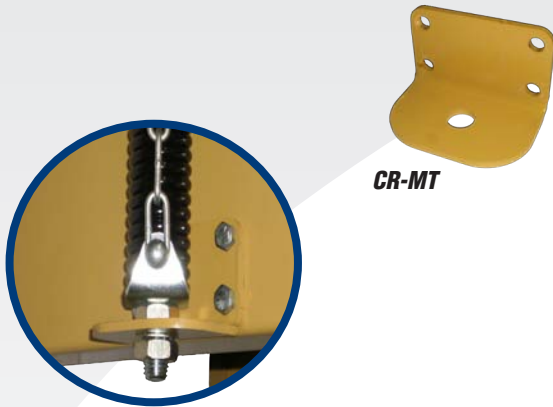

CR-MT

CABLE RETRACTOR MOUNTING BRACKET (CR-MT)

The Cable Retractor Mounting Bracket (CR-MT) allows the BHS Cable Retractor to be mounted on a CWB.

FEATURES & BENEFITS

- Mounts to BHS Charger Wall Brackets by way of (4) 5/16" diameter mounting holes.

CABLE RETRACTOR (CR-1)

The BHS Cable Retractor (CR-1) utilizes a heavy duty spring with safety chain and includes a restrainer for added protection. Mounts to BHS Battery or Charger Stands shelves using pre-drilled mounting holes or to BHS Charger Wall Brackets using a CR-MT (sold separately).

FEATURES & BENEFITS

- Heavy duty spring with safety chain
- Threaded mounting stud with nut
- Supports up to 10' of 2/0 charger leads
- 34" long x 1" diameter pole



CR-1



BATTERY & CHARGER STATIONS

CHARGER ACCESSORIES

MAGNETIC CABLE MOUNT (CR-M)

The BHS Magnetic Cable Mount (CR-M) is a convenient tool that safely secures battery and charger cables preventing cable damage and clutter. Mounts to any flat, ferrous metallic surface such as a charger shelf, wall bracket, or charger case.



FEATURES & BENEFITS

- 3.25" diameter magnet mounts to any flat, ferrous metallic surface
- Allows precise positioning of cable and connector
- Supports up to 10' of 2/0 charger leads
- Magnet is constructed of durable chrome plated steel
- HPDE acid resistant clamp

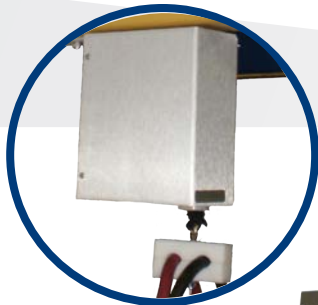

HEAVY-DUTY CABLE RETRACTOR (CCR-12HD)

The BHS Cable Retractor - Heavy Duty (CCR-12HD) holds larger cables and bolts directly onto the charger. It's adjustable and lightweight. Mounts to BHS Battery Stands, Chargers Stands, or Charger Wall Brackets by way of (2) 3/8" diameter mounting holes.

FEATURES & BENEFITS

- Bolts to charger, charger bracket, or charger shelf
- Adjustable tension spring
- Reaches up to 10'
- Supports up to 12' of 4/0 charger leads
- HPDE acid resistant clamp



P.O. Box 28990
St. Louis, MO 63132 USA
1.800.BHS.9500
Fax: 314.423.6444
E-mail: sales@bhs1.com
Web: BHS1.com

Specifications are subject to change without notice. ©2010, Battery Handling Systems Inc. St. Louis, MO
Data Sheet: SF-2200 08/10