

VIPERSORT

Right Angle Sortation Conveyor

The Model ViperSort is a right angle sortation conveyor used to sort small to medium size products. The ViperSort utilizes a patented design which enables the sorting of cylindrical products, extremely thin items such as blister packs, vinyl envelopes and other problematic items.

- 4 Widths Available
- Sorts Up To 120 Items Per Minute
- Blue Acetal Open Grid 1" Pitch Cleated Plastic Belt
- Flexible Sort Locations
- Adjustable MS-Type Floor Supports Available
- Close Divert Centers



ViperSort with Gravity Cantenary (Lengths of 11' to 80', 6" Increments)

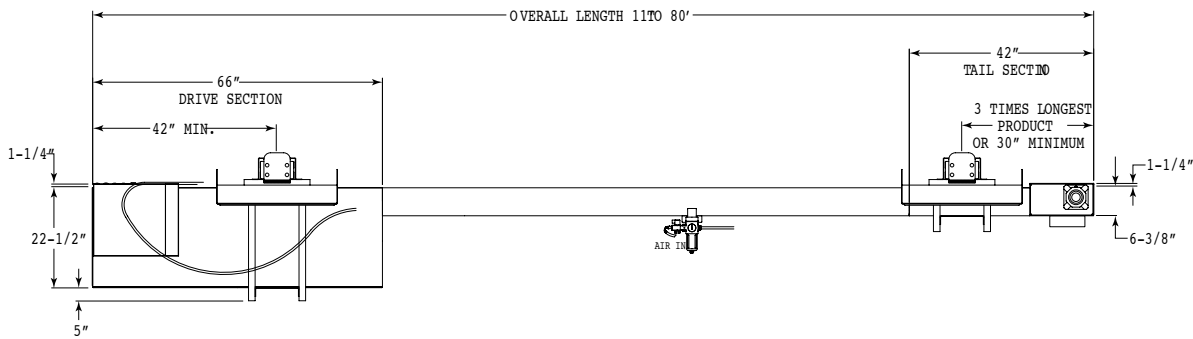

ViperSort with Pneumatic Take-Up (Lengths over 80', 6" Increments)

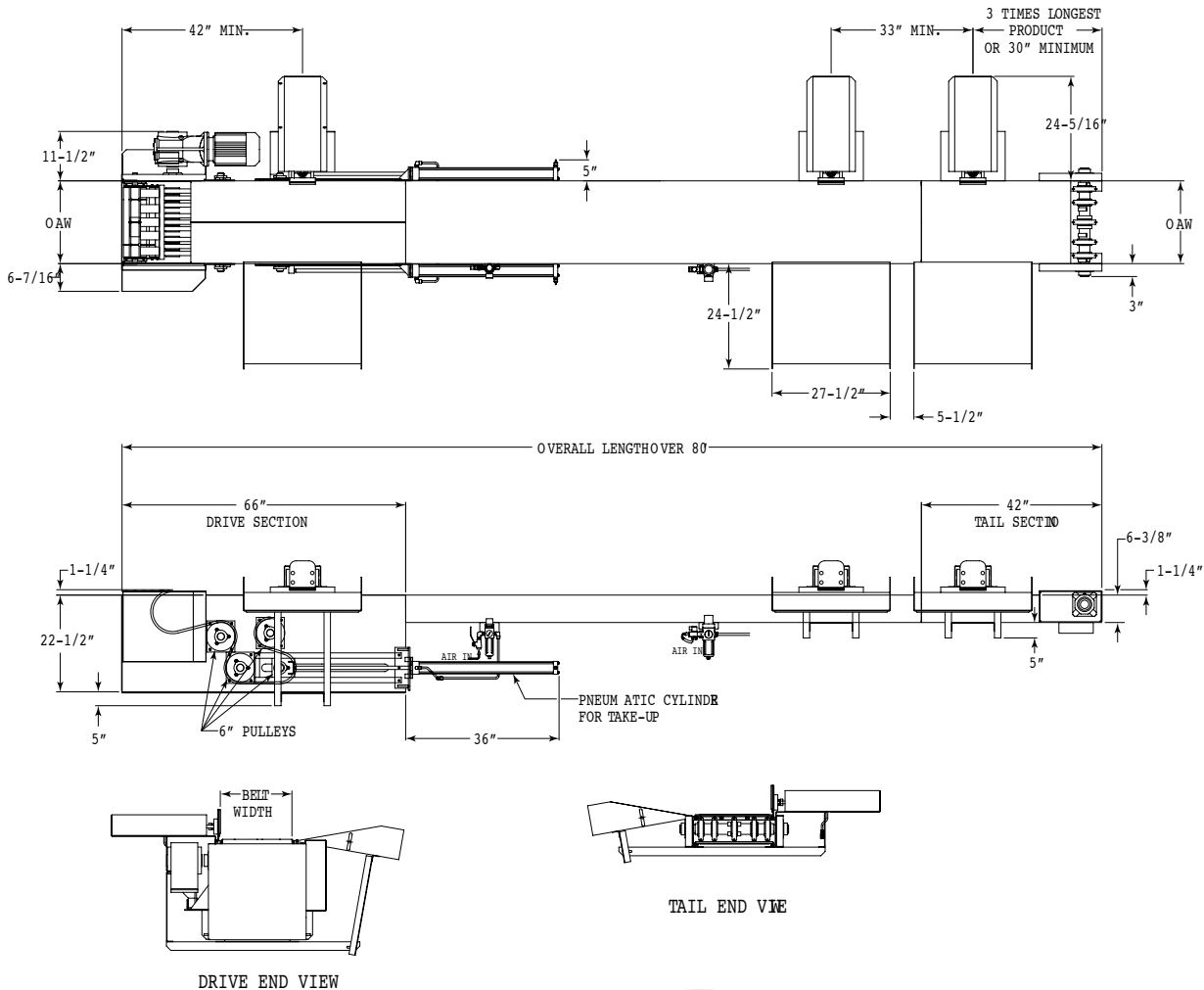

• STANDARD SPECIFICATIONS - PUSHER

VIPERSORT

RATE—Up to 120 items per minute depending on item size and weight.

CAPACITY—Maximum unit package weight 25 lbs. (See Rate).

PACKAGE SIZE—24 in. long maximum, over 24 in. contact factory.

AIR CYLINDER—High speed 32mm dia. bore x 325mm stroke guided cylinder.

AIR REQUIREMENTS—Working pressure 60 psi. Free air consumption at 60 psi, 0.1 cu. ft. per cycle.

AIR VALVE—24 volt DC double solenoid 4-way air valve.

AIR FILTER, REGULATOR WITH LOCKOUT—Supplied for main air supply line with ¾ in. NPT ports. Maximum of 6 diverts per regulator.

CHUTE—Adjustable 27 ½ in. wide x 24 in. long x 12 ga. formed steel chute powder painted.

STROKE SENSOR—Two 24VDC sensors, adjustable for setting stroke length and determining home position.

• STANDARD SPECIFICATIONS - CONVEYOR

BELT—Blue, acetal open grid 1 in. pitch with cleat every 2.1 in.

BED—6 ¾ in. deep x 12 ga. formed steel bed powder painted with aluminum guide rail extrusion capped with UHMW wearstrip placed on bed for carry way.

DRIVE SPROCKET—9.7 in. PD split steel sprocket 2 ½ in. square bore.

TAIL SPROCKET—6.1 in. PD split steel sprocket 2 ½ in. square bore.

RETURN CARRY WAY—Aluminum guide rail extrusion capped with UHMW wearstrip placed on inside of bed bottom flange.

TAKE UP—80 ft. and less have gravity cantenary, over 80 ft. has pneumatic take-up with 6 in. pulleys.

BEARINGS—4 Bolt, 1 ¼ in. bore cast iron sealed, pre-lubricated, self-aligning ball bearing with eccentric lock collars.

DRIVE—Shaft-mounted gearmotor 230 V or 460 V - 3 Ph. 60 Hz.

CAPACITY—Maximum unit package weight 25 lbs. For maximum conveyor distributed load, contact factory.

AIR FILTER, REGULATOR—Use with pneumatic take-up. Supplied for main air supply line with ½ in. NPT ports. Required working pressure of 15-20 psi, 20 psi max.

VARIABLE SPEED CONTROLLER—Provides smooth acceleration of drive motor and speed variations if necessary. Maximum belt speed - 120 FPM.

APPLICATION NOTE: Products placed on the ViperSort must be justified to the pusher side of the conveyor to prevent mis-diverts and damaging of products.

Overall Width	Belt Width	Base Weight with Gravity Catenary	Base Weight with Pneumatic Catenary	Conveyor Weight Lbs. Per Foot
13 ¼"	12"	428 lbs.	599 lbs.	14.3
15 ¼"	14"	448 lbs.	618 lbs.	15.7
17 ¼"	16"	463 lbs.	639 lbs.	17.1
19 ¼"	18"	488 lbs.	658 lbs.	18.5

$$\text{Total Weight} = \text{Base Weight} + (\text{Conveyor Weight per Foot} \times (\text{Overall Length} - 9 \text{ ft.})) + (115 \text{ lbs.} \times \text{Num. of Diverters})$$

• OPTIONAL EQUIPMENT

FLOOR SUPPORTS—MS Type floor supports are available with a wide range of adjustment. Specify top of belt or roller elevation. One support required at every bed joint and ends of conveyor. Holes in feet for lagging to floor. Knee braces recommended above MS-6 support.

PROSORT LOGIX VIPERSORT CONTROL PACKAGE—Provides complete controls for proper sorter operation. Contact factory for details.

BELT—Blue acetal flat top 1 in. pitch - less cleats.

DUAL SIDED DIVERTERS—Pushers located on both sides with staggered centers